

# OMRON®

## Focused Automation/Core Technology Solutions

### Optical Character Verification

### Vision Sensors



#### Industry:

Food and Beverage



#### Applications:

Post application inspection of Date Codes, Lot Codes, SKUs, serial numbers and other text based codes from automated printing machines and marking systems.



#### Problem:

Accurate and readable date codes, lot codes, and other text information printed on most food items provide vital expiration and traceability information. Products with unreadable codes become defective even if the product inside is good because retailers and consumers cannot verify the product quality. This results in wasted product, costly returns and loss of consumer confidence in the brand. 100% inspection is required to ensure the codes are accurate, complete and legible, as well as to monitor the operation of the marking equipment.



#### Omron "FACTS" Advantage

##### F160-2 Vision Sensor F210 CF Vision Sensor

Omron's F160-2 and F210 CF vision sensors enable food and beverage producers to conduct 100% inspection of printed codes in-line, at line speeds with accurate and reliable determination of readability. The vision sensors feature robust internal character libraries and have advanced OCV/OCR software designed exclusively to address text code verification applications.

The F210 CF's exclusive software automatically updates system date codes without intervention and allows the use of templates to quickly setup inspection for common codes such as "Best Before" or "Expires On."



#### Application Diagrams

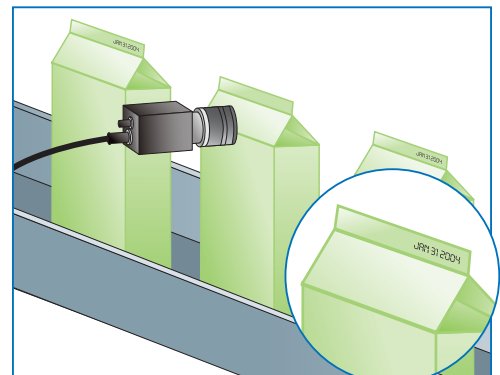

Verifying date on gable top cartons.

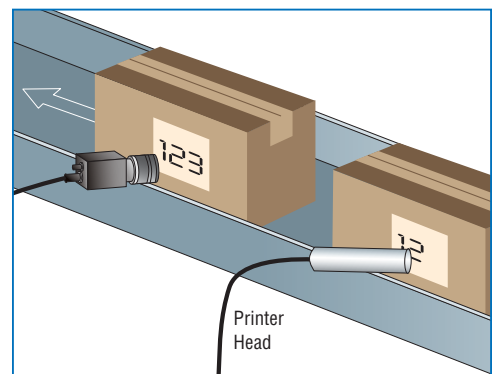

Verifying label information on cartons immediately after printing.

### Optical Character Verification Application Details

#### Issue

The FDA, customers and internal quality standards mandate that in many cases date/lot codes and other text information be printed on most food and beverage packaging to ensure consumer protection and provide for better traceability of products. Because this information is critically important from both customer use and company liability perspectives, it is absolutely essential that the information is complete, accurate, and legible.

Most producers use automated printing or marking machines to apply these codes. However, because a variety of errors can prevent the codes from being properly marked on products, it is essential that producers inspect these codes following printing to ensure code quality and legibility.

#### Cause

Despite advances in in-line marking systems, marking errors can occur. Typical causes include:

- Poor printer maintenance
- Poor printer adjustment
- Insufficient ink/wrong ink
- Clogged ink jets
- Worn stamping pads or dies
- Product movement during printing

Any of the above will result in smeared, elongated, truncated, deformed, or missing characters or codes.

All of these problems are usually easily corrected with minimal waste and effort if operators or maintenance teams are notified immediately of the problem.

#### Omron's Unique Solution

Omron offers two vision sensors with advanced character verification image processing functions and robust internal character libraries that do not require character teaching and make character code verification reliable, easy and 100% verifiable.

Omron's unique and robust QUEST Optical Character Recognition algorithms provide accurate and reliable character recognition even when characters vary in size, shape, density and sharpness. The technology works hand in hand with the sensors' extensive internal character libraries that cover the most common fonts, including dot matrix fonts, and eliminate the need for the user to "teach" individual characters.

For added versatility in code verification, the F210 CF offers additional functionality to automatically update its internal reference date and compares the printed date code to verify its accuracy, eliminating the need for changing or updating the comparison codes manually. In addition, its standard functionality inspects several date code types including "manufactured On" date, "Best Before" and other common types with easy reference configuration.

Both the F210 CF and F160-2 offer easy step-by-step, menu driven setup tools with no PC or software programming necessary. All setup is done with a simple hand-held keypad. The vision sensors also provide a live video output to monitor inspection images in real time.

Omron's unique ability to offer a total automation solution, not just a vision product solution, is backed by our expertise integrating inspection with control systems. We offer local, national and international support to develop solutions and support our customers.

#### Results

Powerful and robust character recognition and verification algorithms built into the F210 CF and F160-2 vision sensors allow food and beverage processors to benefit from 100% date, lot and other text code inspection quickly and easily and in compliance with all regulations. No PC or special software is required. All functionality is built into the controller out of the box. Simple step-by-step setup processes simplify setup and facilitate quick changeovers.

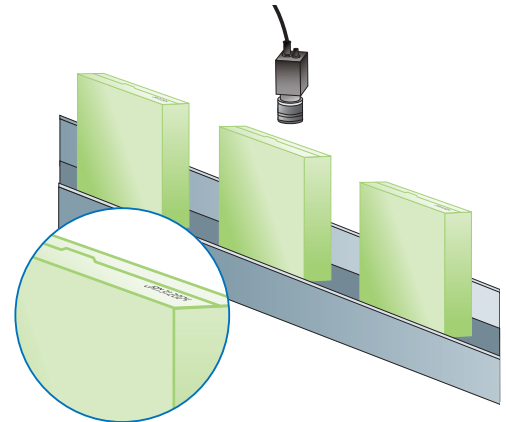

Milk carton

Coffee creamer jar



Cheese jar

Dog food can

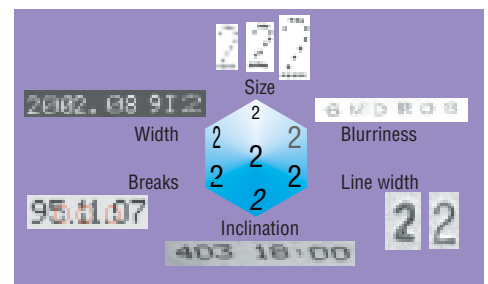

Print quality issues

**OMRON**  
 OMRON ELECTRONICS LLC  
 Schaumburg, IL  
[www.omron.com/oei](http://www.omron.com/oei)  
 OMRON CANADA, INC.  
 Toronto, Ontario  
[www.omron.ca](http://www.omron.ca)

Q101-E-01 02/04/1M  
 © 2004 OMRON ELECTRONICS LLC  
 Printed in the U.S.A.

<b>UNITED STATES REGIONAL SALES OFFICE</b>		<b>CANADA REGIONAL SALES OFFICE</b>	
847.843.7900		416.286.6465	
For US technical support or other inquiries: 800.556.6766		<b>BRAZIL SALES OFFICE</b>	
<b>MEXICO SALES OFFICES</b>		55.11.5564.6488	
Florida 954.227.2121	Ciudad Juarez 656.623.7083	<b>ARGENTINA SALES OFFICE - CONO SUR</b>	
Mexico, D.F. 555.534.1195	Monterrey, N.L. 818.377.4281	114.590.2408	

[www.foodbeverage.omron.com](http://www.foodbeverage.omron.com)